

HCDC®  
xikentech.com

**Automatic Transfer Switch**  
**AC 120V / 230V, 20 / 30 Amp**  
**Model: HD067 Series**

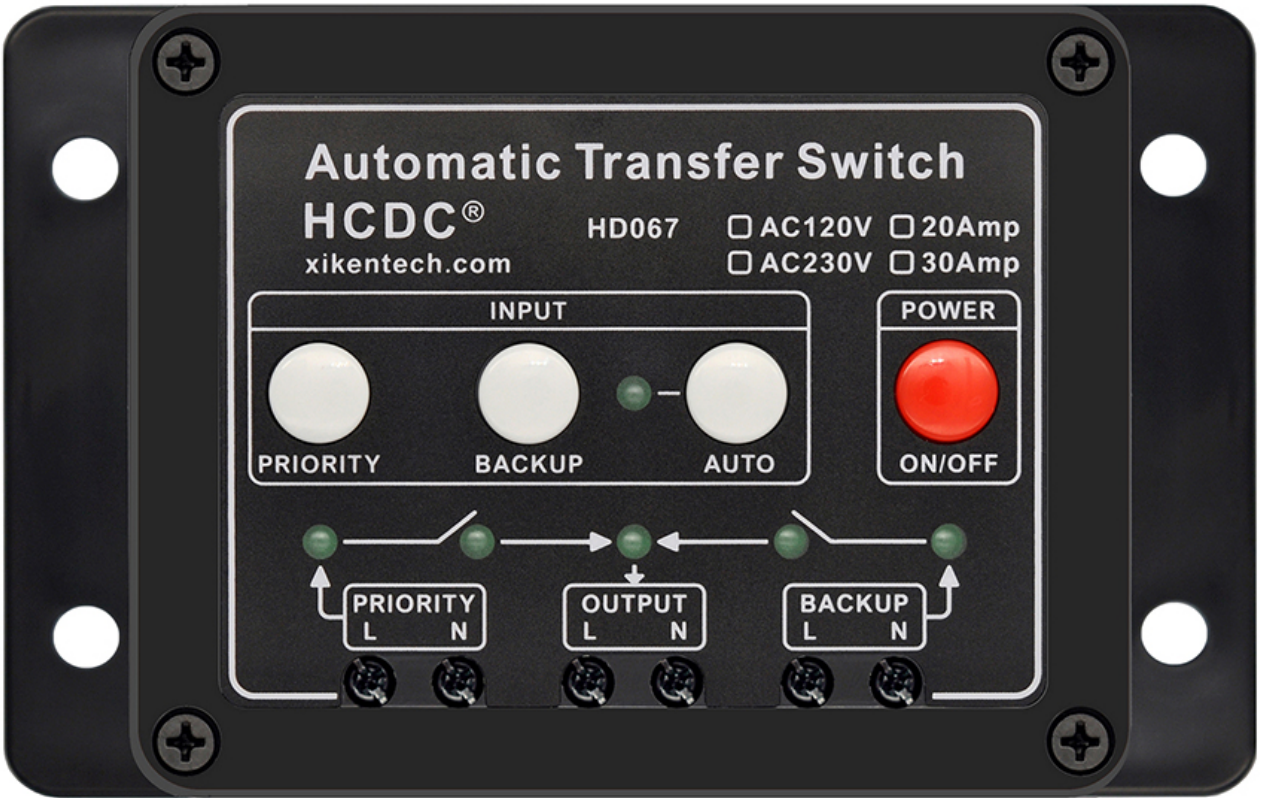

## FEATURES:

- HCDC HD067 Automatic transfer switch, voltage AC 120V / 230V current 20 / 30 Amp 4 versions are available. Select input source automatically or manually. With output on/off control function. With power-off memory function.
- In automatic mode (press the AUTO button), the automatic selection priorities are: 1 – PRIORITY, 2 - BACKUP. If you want to manually select an input source (manual mode), you can directly press button: PRIORITY or BACKUP. When you want to return to automatic mode, just click the AUTO button.
- Power ON/OFF control function: When you want to disconnect the load power, just click the ON/OFF button, it will immediately disconnect the live wire and the neutral wire at the same time, and all indicator LEDs will go out.
- Multiple indicator lights allow you to clearly see the product's input source status, output status, operating mode, and the status of the internal relay switch.
- It has a power-off memory function, and the next time it is powered on, it will return to the state before the power-off, which will not cause unpredictable consequences. The memory includes the operating mode, input source, and output switch status.
- Transfer time less than 30mS (0.03 second), for most smart devices or computers, the switching action of 30mS time will not affect their normal operation.
- The live wire and neutral wire of each input source are controlled by different high-power SPST relays, ensuring that there will be no power arcing and no creepage between different input sources. The design is specially optimized to not cause your GFCI protector to trip for no reason.

## SPECIFICATIONS:

- Input or Output Voltage: AC 90 - 135V 50/60Hz (for AC120V version)  
AC 180 - 250V 50/60Hz (for AC230V version)
- Maximum Load Current: Available in 20 and 30 Amp versions.
- Transfer Time: < 30 millisecond.
- Terminal Block: Wire 20 - 6 AWG / 10 Square millimeters, Stripping length 10mm, Screw Metric M4
- Case material: ABS plastic

## CIRCUIT DIAGRAM:

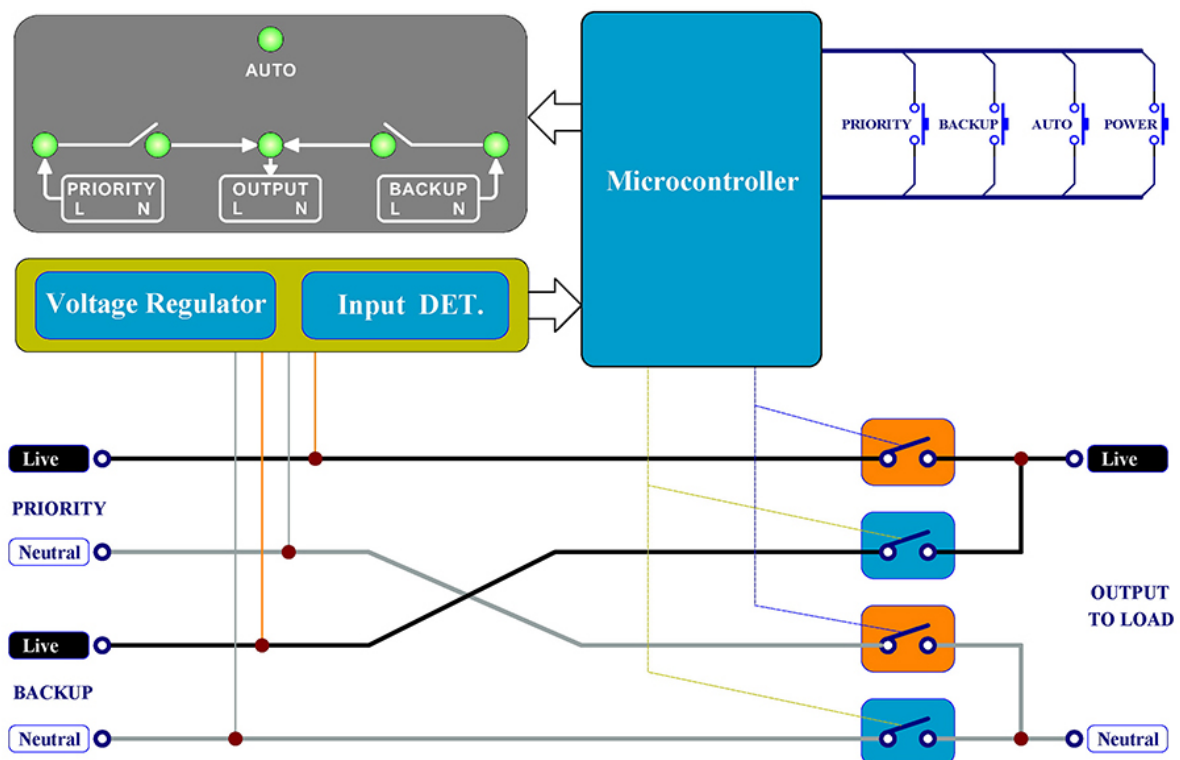

**DIMENSIONS:**

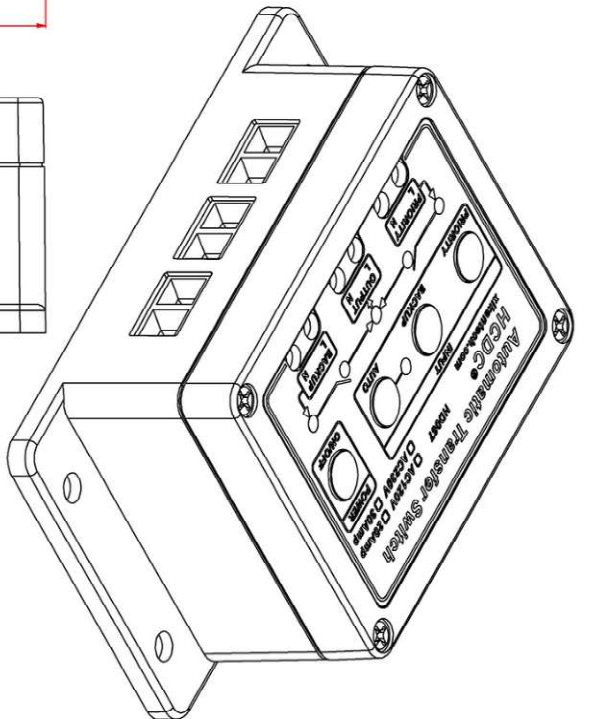
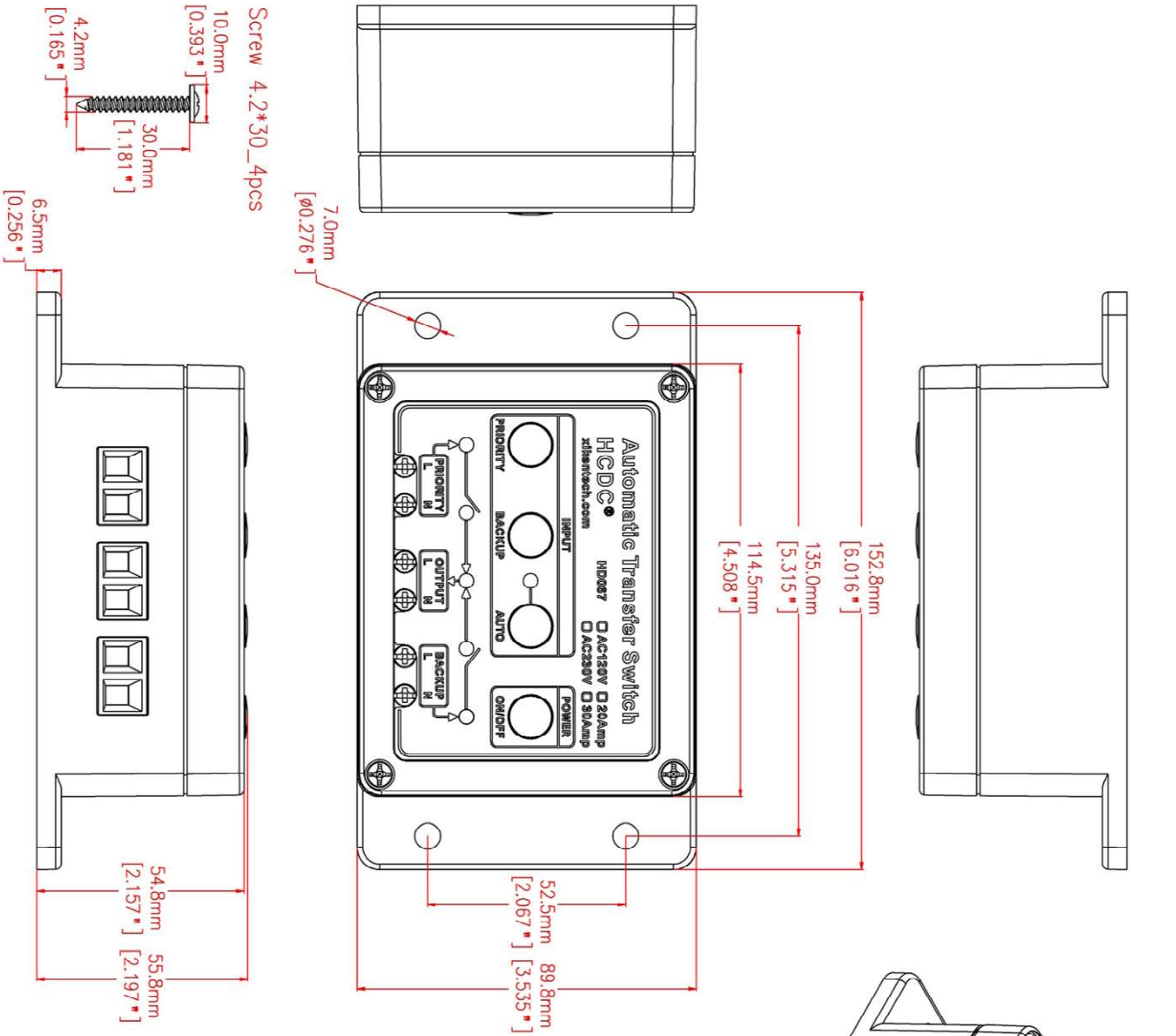

<b>HCDC® xikentech.com</b>		
MODEL NO:	HD067	SKU: HD067
PROJECTION:		UNIT: mm / inch

## **IMPORTANT**

- **THIS MODULE OPERATES ON A HAZARDOUS VOLTAGE !**
- **DISCONNECT AC POWER DURING INSTALLATION !**
- **Installation must be done according to local regulations and standards. If any doubt, consult a licensed technician.**
- **This module is not suited for portable applications.**

## **DANGER !!!**

- **Do not open the housing in order to avoid the risk of electroshocks.**
- **This module operates on a dangerous AC voltage !**
- **All repairs should be executed by qualified technicians.**

## **SAFETY INSTRUCTIONS !!!**

- **Do not attempt to disassemble the unit as it does not contain any parts that are to be serviced by the user. (Tampering voids warranty)**
- **Do not touch unused terminals when the module is connected to the AC power.**
- **Handle the module gently and carefully. Dropping it can damage the circuit board and case.**
- **Never exceed the protection limit values indicated in the specifications.**
- **As safety requirement vary, please check with your local authorities.**
- **Disconnect the module from the AC power before connecting new devices.**
- **Wipe the device with a dry and clean cloth. Do not use detergents or other liquids that may damage the housing.**
- **Keep the device away from children.**
- **Facilitate the operation of the device by familiarising yourself with its adjustments and indications.**
- **Xiken-Tech and HCDC modules are not suitable for use or as part of life support systems, or systems that might create hazardous situations of kind.**