

**HCDC®**  
**xikentech.com**

**2 SPDT 16Amp Pluggable Power Relay Module**  
**Model: HD047 Series**

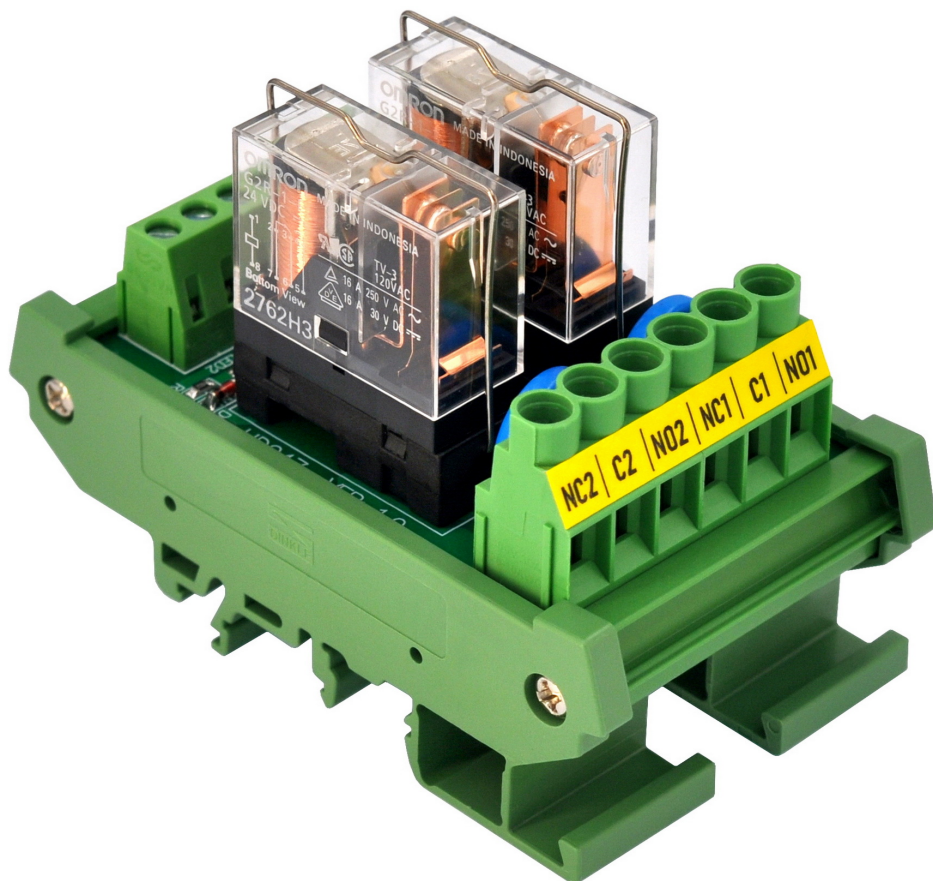

## Feature:

- Omron G2R-1-E industrial power relays, switching current up to 16 Amp at 250VAC (or 30VDC).
- Support control mode: DC Common positive (Sink, NPN), DC Common negative (Source, PNP), or AC mode.
- LED indicator for each relay channel.
- Relay coil protection by means of a freewheeling diode.
- Easy to replace pluggable relays.
- Output switch COM to N/O with metal oxide varistor, surge protection up to 4500A(8/12μS).
- High quality fireproof nylon material DIN rail mount carrier (UL CE certified, not China low quality carrier), can support width 35mm / 32mm / 15mm rail.
- UL CE CQC certified terminal blocks. 94-V0 FR-4 fiber glass PCB.

## Characteristic Parameters:

SKU	HD047-12V	HD047-24V
Relay Part Number	G2R-1-E 12VDC	G2R-1-E 24VDC
Operating Voltage Range	DC 9.0 - 18V AC 9.0 - 15V	DC 18 - 36V AC 15 - 30V
Operating Current (Each channel)	32mA @12V	16mA @24V
<b>Output Switch:</b>		
For AC	Resistive load: 250VAC, 16Amp Inductive load: 250VAC, 8Amp	
For DC	Resistive load: 30VDC, 16Amp Inductive load: 30VDC, 8Amp	
Mechanical endurance	20,000,000 operations min. (at 18,000 operations/hr)	
Electrical endurance	100,000 operations min. (at 1,800 operations/hr under rated load)	
<b>Terminal Blocks:</b>		
Input	Wire range 26AWG to 12AWG / 2.5mm square, Pitch 5.0mm / 0.197". Strip length 7mm. Screws - M2.5	
Output	Wire range 26AWG to 10AWG / 4.0mm square, Pitch 7.62mm / 0.3". Strip length 8mm. Screws - M3	

**Schematic:**

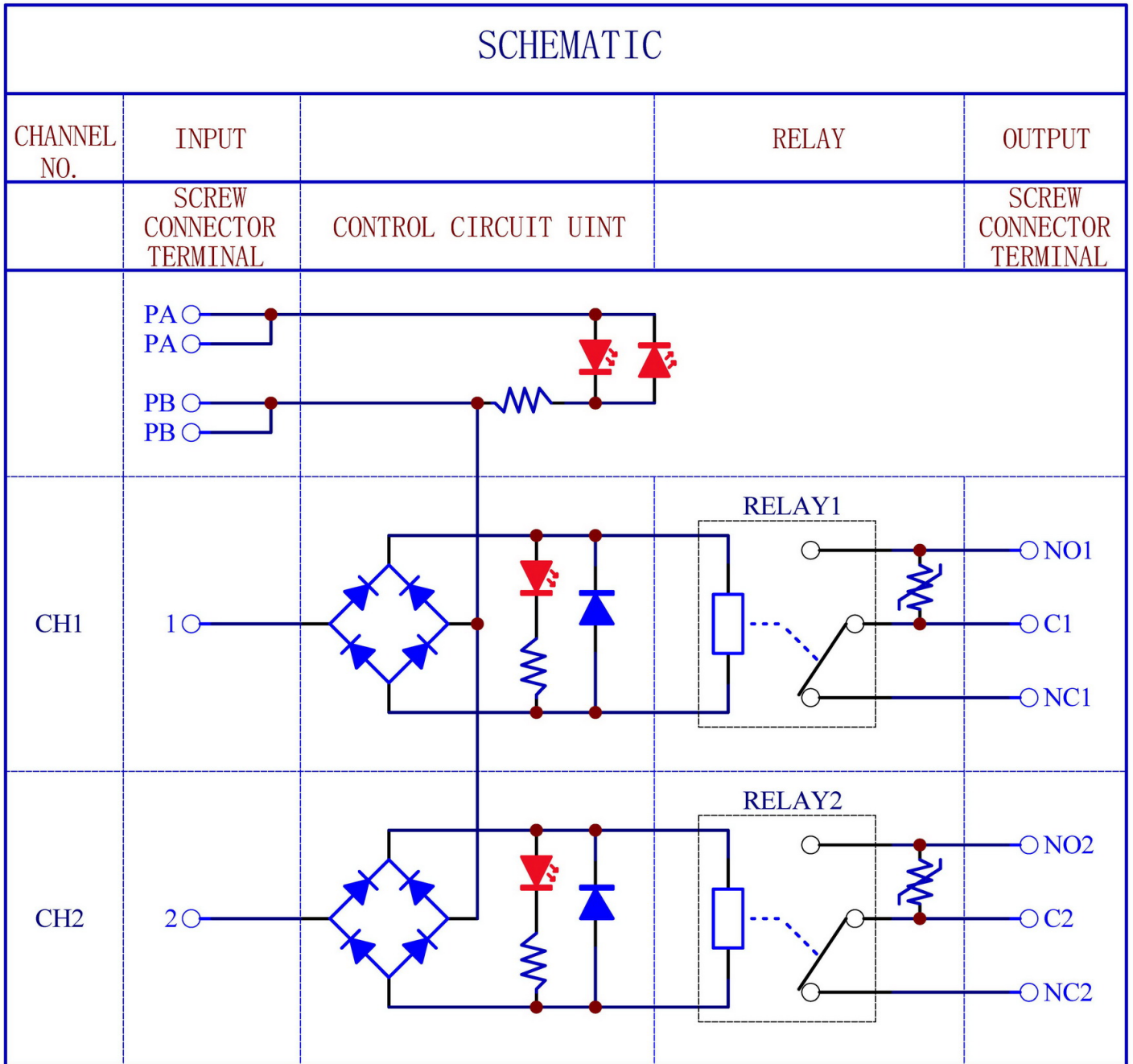

# Control Mode Connects (Sink, Source, AC):

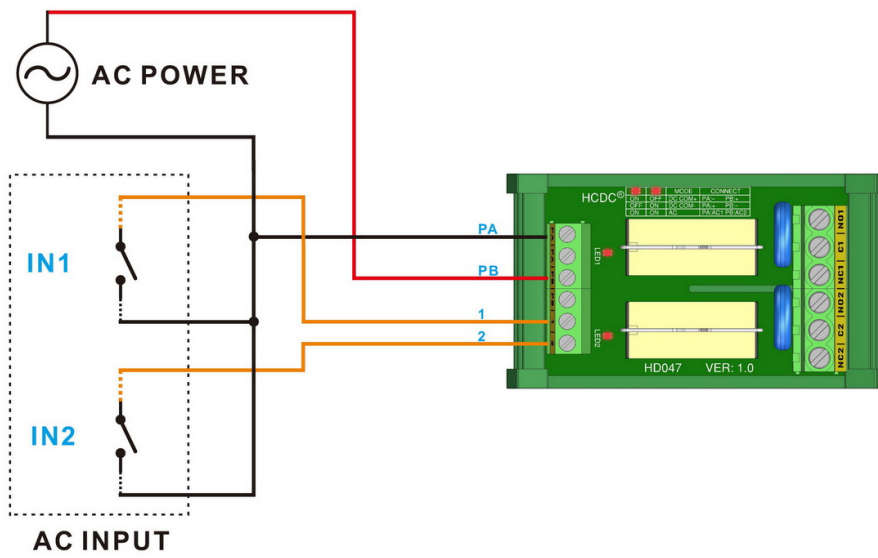
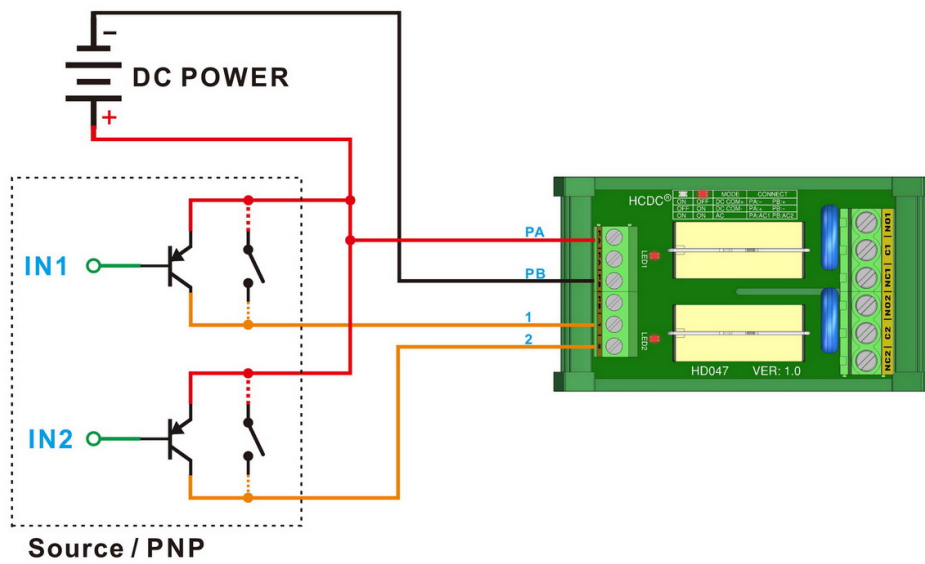
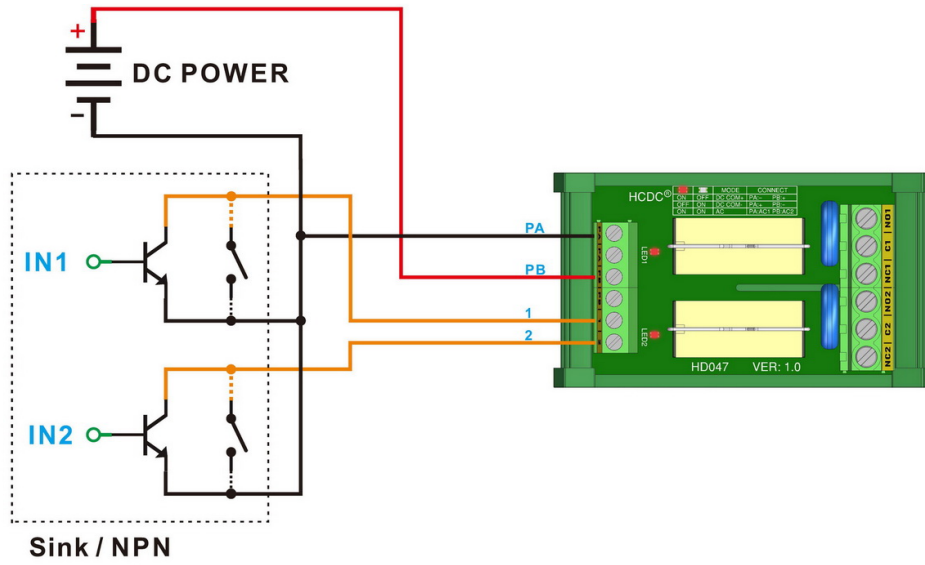

**Dimensions:**

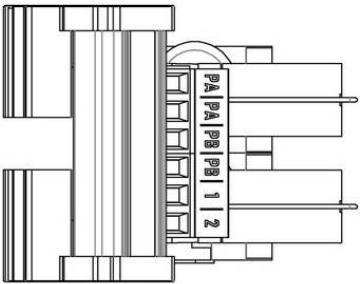
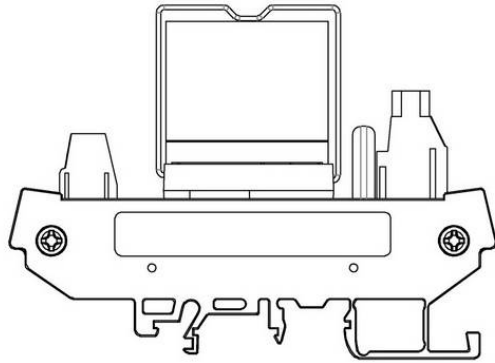
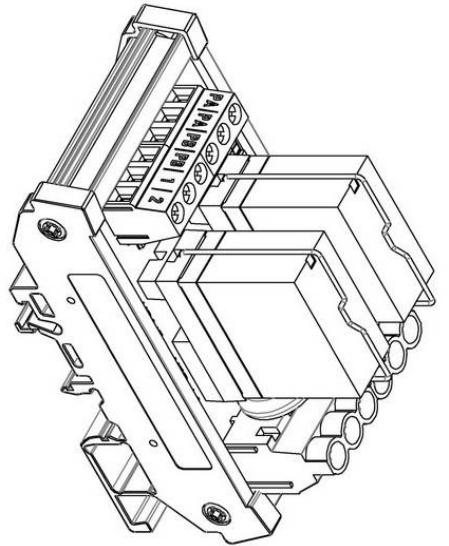
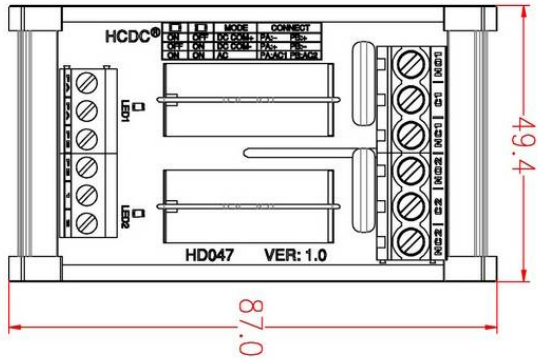
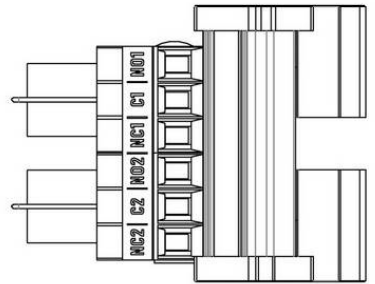
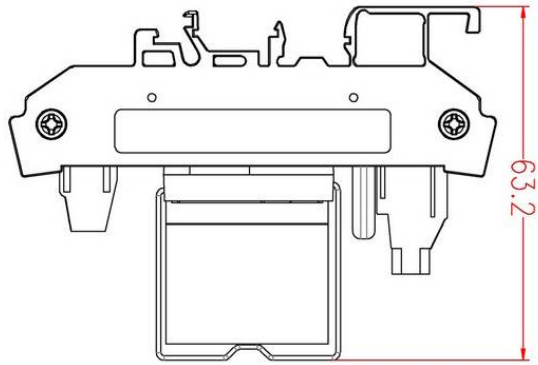

<b>HDCD<sup>®</sup></b>		<b>xikentec.com</b>	
MODEL NO.:	HD047	DATE:	2022. 10. 21
PROJECTION:		UNIT:	mm