

OONO[®]

czh-labs.com

Plastic Enclosure Wired

10 Amp Power Relay Module, SPST-NO + Override Switch

Model: F-1079 series



Features:

- Polycarbonate plastic enclosure with a NPT 1/2" mounting nipple, LED indicator and pre-wired for a money-saving installation that is easy and quick.
- Input control signal version: AC/DC 5V, 12V, 24V, and AC 120V, 208-277V five versions selectable. When controlled by a DC signal, the two wires on the input end do not need to care about their polarities.
- Output switch SPST (Single Pole Single Throw), rated current 10A 125VAC or 6A 250VAC / 30VDC.
- With override switch function, the output can be manually set to ON or OFF state without being affected by the input signal. It can also be set to AUTO mode, in which the output state is controlled by the input signal.
- This is a simple and practical passive relay module, which is very convenient to use. All wires lead out via 1/2" mounting nipple, it can be flexible mounting with your junction box / outlet box. Two screw mounting holes are convenient for you to fix it on the wall or wooden board.
- Packing list: 1x relay module, 1x NPT 1/2" Zinc alloy conduit locknut, 2x M3x50mm screws.

Specifications:

Input Control Signal:

	F-1079 5V	F-1079 12V	F-1079 24V	F-1079 120V	F-1079 240V
Action voltage	AC 4 - 7V or DC 4.5 - 7V	AC 10 - 14V or DC 10 - 16V	AC 20 - 28V or DC 20 - 30V	AC 100 - 130V	AC 208 - 277V
Action current	72mA @5V	30mA @12V	15mA @24V	16mA @120V	16mA @240V

Output Switch:

	F-1079 5V 12V 24V 120V 240V
Rated load	10A 125VAC, 6A 250VAC, 6A 30VDC (resistive load).
Mechanical endurance	10,000,000 operations
Electrical endurance	50,000 operations at 250 VAC, 5 A (resistive load, room temp., 5s on 5s off) 50,000 operations at 28 VDC, 5 A (resistive load, room temp., 5s on 5s off)

Input and Output Status:

Input Signal	LED	Output Switch
Low (or no connect)	OFF	N/C to Comm connected and N/O to Comm disconnect
High	ON	N/C to Comm disconnect and N/O to Comm connected

Dimensions:

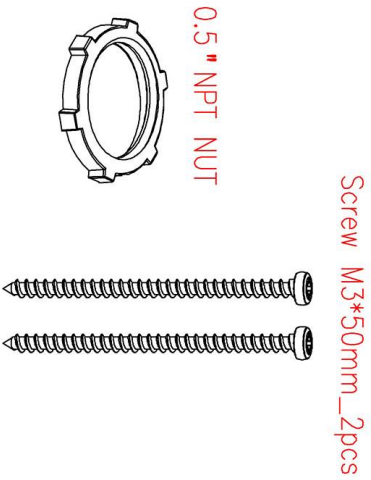
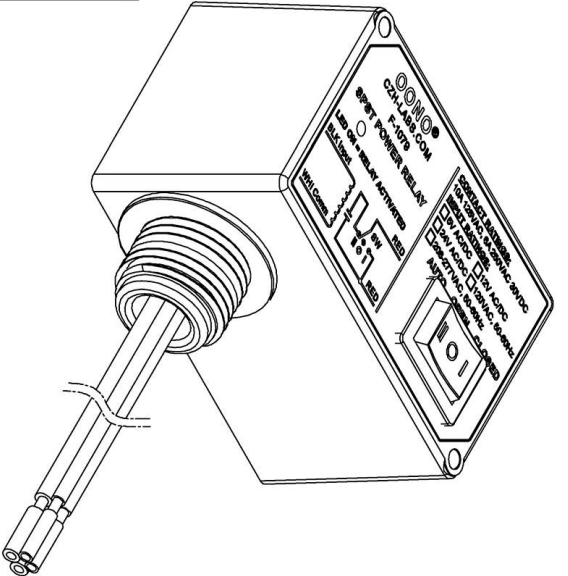
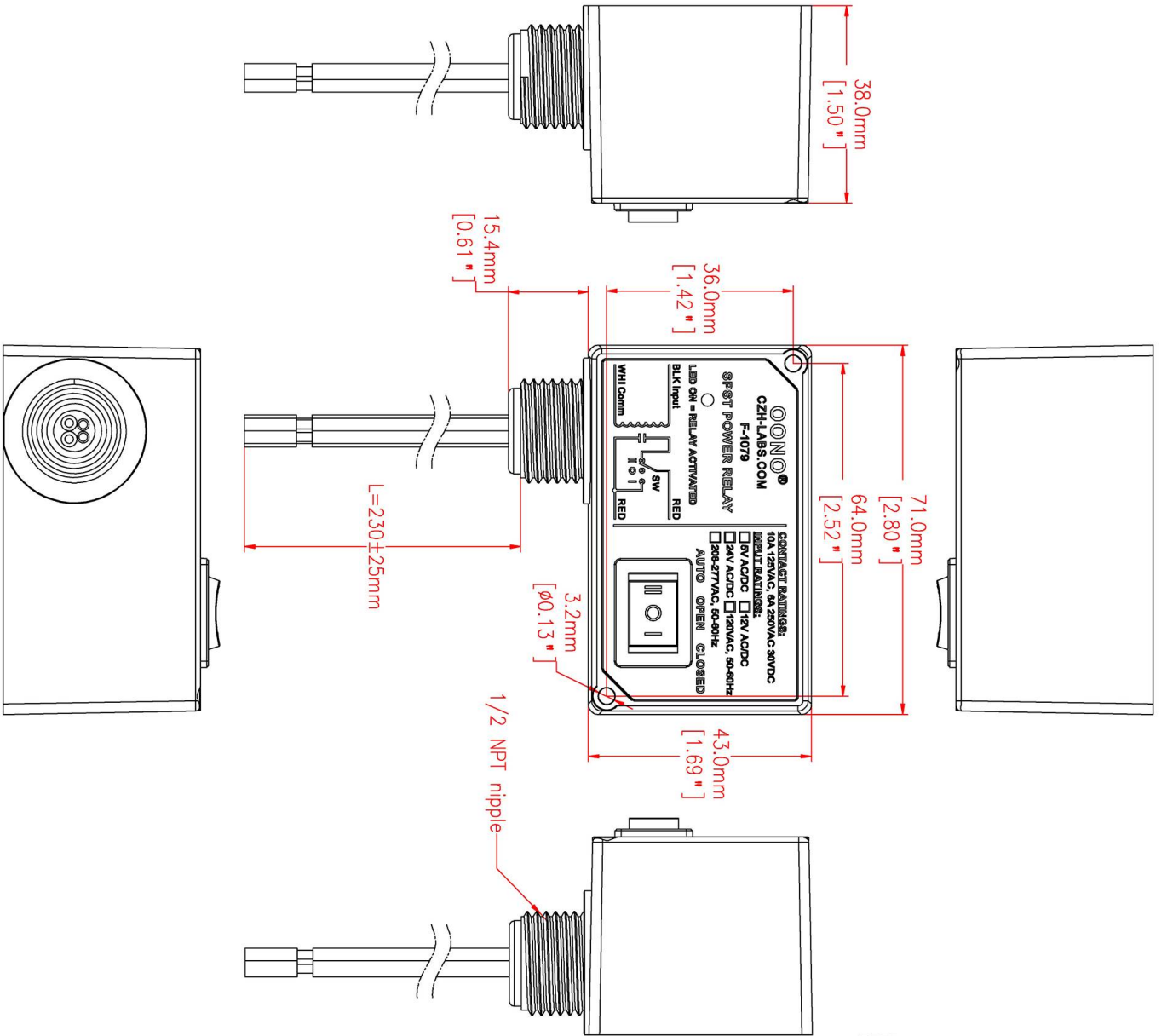

OON0 ®		czh-labs.com	
MODEL NO:	F-1079	SKU:	MD-F1079-1
PROJECTION:		UNIT:	mm