

OONO®
CZH-LABS.com

Wired DC-DC Isolated Solid State Relay Module

Model: F-1049

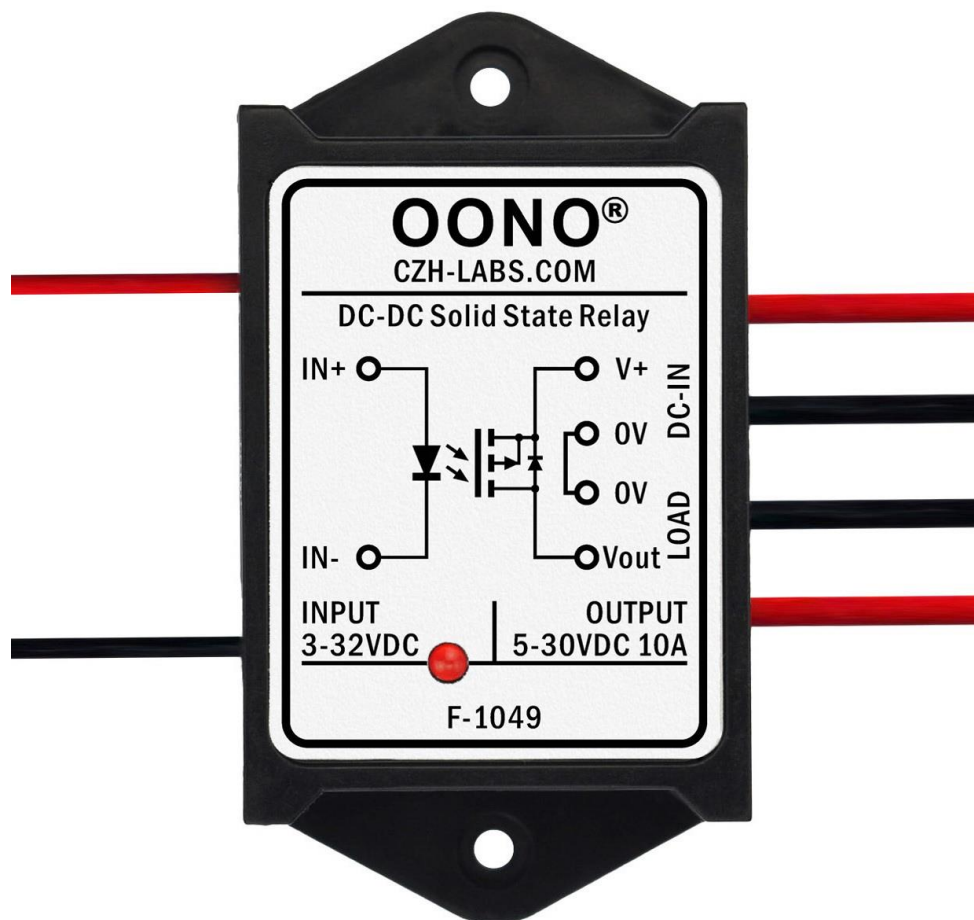

Features:

- Photocoupler isolation between input control signal and controlled power, isolation surge voltage up to 5000V.
- Input signal turn-on voltage DC 3 to 32V, turn-off voltage DC 0 to 0.8V. LED indication for relay turn-on.
- Output voltage range: DC 5 to 30V. Maximum on-state average current 10 Amp. Maximum on-state current 20 Amp (< 2 second). Non repetitive surge peak on-state current: 160 Amp (<400uS). Maximum on-state resistance 8 milliohms(0.008 ohm).
- This is a simple and practical solid state relay module, which is very convenient to use, for Arduino, Raspberry Pi, ESP32, PLC or other projects. The GPIO of these controllers are directly connected to this relay input to control the 5 to 30V high current DC power.
- Compact ABS plastic case and wires connect for easy mount. Two screw mounting holes are convenient for you to fix it on the wall or wooden board. Of course, you can also choose not to lock the screw.
- Compared with traditional electromagnetic relays, it has the advantages of long operating life, rapid on-off, no ignition arc and bounce, thus reducing electromagnetic interference. In addition, its action is quiet and does not produce annoying "ka-da" sounds.

Characteristic Parameters:

Input Signal Control Terminal:

Action Voltage: 3 ~ 32 VDC.

Current: 5mA at 3VDC, 6mA at 5VDC, 8mA at 12VDC, 11mA at 24VDC, 13mA at 32VDC.

Turn off voltage: 0 ~ 0.8 VDC.

In-Out isolation surge voltage: 5000V.

Output Terminal:

Load voltage range: 5 to 30 VDC.

Max. on-state average current: 10 Amp.

Max. on-state current: 20 Amp (< 2 second).

Non repetitive surge peak on-state current: 160 Amp (<400uS).

Max. on-state resistance: 8 milliohms(0.008 ohm)

Load type: General purpose.

Turn-on delay time: 5 to 7 uS

Turn-off delay time: 60 to 70uS

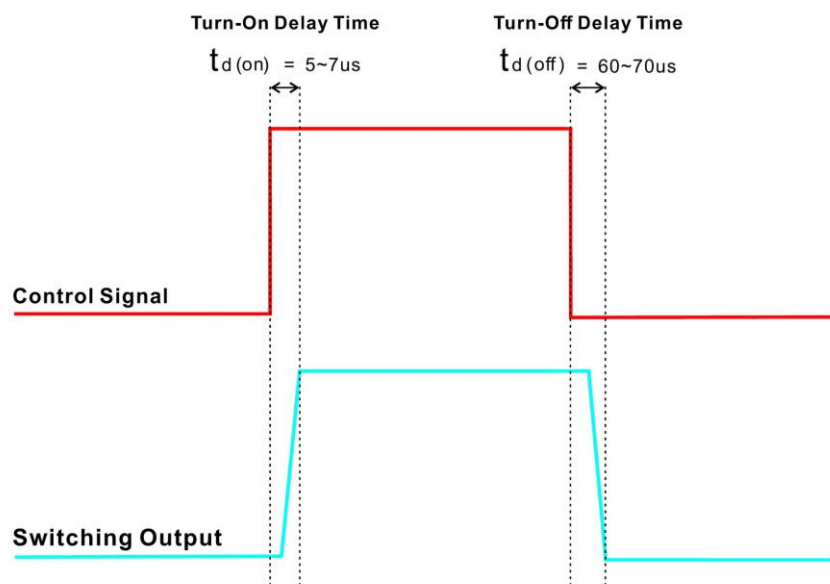

Schematic:

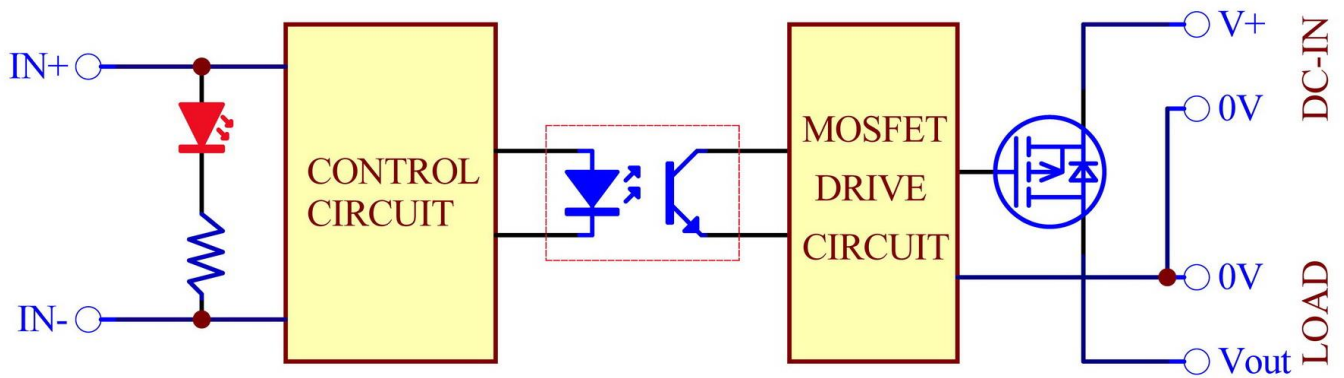

Typical Connection Diagram:

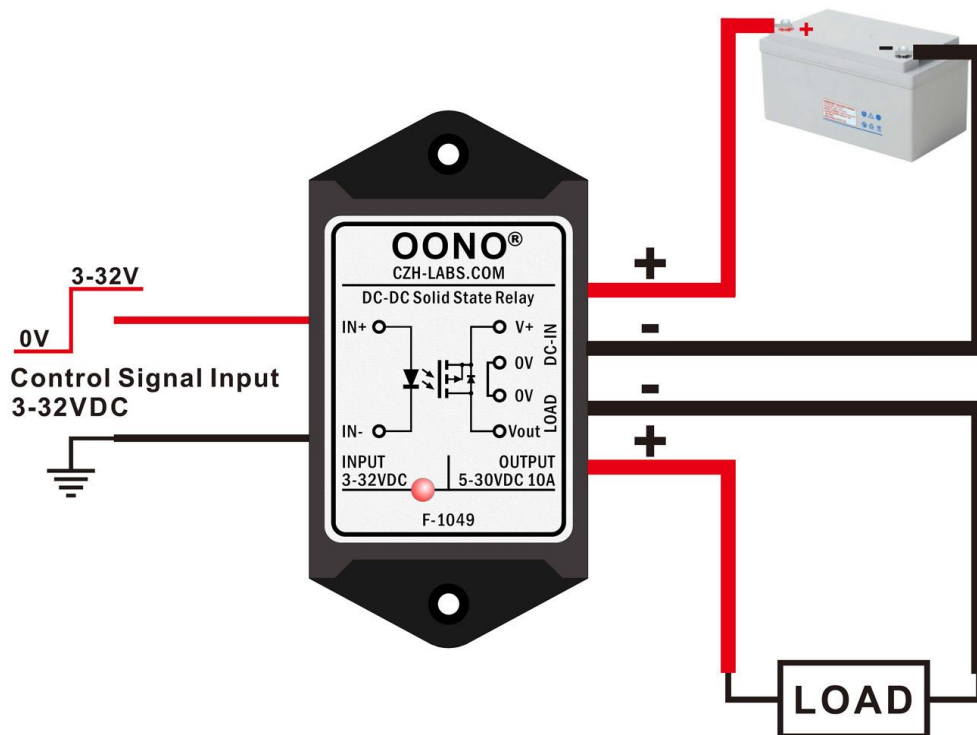

Dimensions:

